

Dell Networking S6000 Installation Guide

Publication Date: October 2013



Notes, Cautions, and Warnings

 **NOTE:** A NOTE indicates important information that helps you make better use of your computer.

 **CAUTION:** A CAUTION indicates either potential damage to hardware or loss of data and tells you how to avoid the problem.

 **WARNING:** A WARNING indicates a potential for property damage, personal injury, or death.

Information in this publication is subject to change without notice.

© 2013 Dell Networking. All rights reserved.

Reproduction of these materials in any manner whatsoever without the written permission of Dell Inc. is strictly forbidden.

Trademarks used in this text: Dell™, the DELL logo, Dell Precision™, OptiPlex™, Latitude™, PowerEdge™, PowerVault™, PowerConnect™, OpenManage™, EqualLogic™, KACE™, FlexAddress™ and Vostro™ are trademarks of Dell Inc. Intel®, Pentium®, Xeon®, Core™ and Celeron® are registered trademarks of Intel Corporation in the U.S. and other countries. AMD® is a registered trademark and AMD Opteron™, AMD Phenom™, and AMD Sempron™ are trademarks of Advanced Micro Devices, Inc. Microsoft®, Windows®, Windows Server®, MS-DOS® and Windows Vista® are either trademarks or registered trademarks of Microsoft Corporation in the United States and/or other countries. Red Hat Enterprise Linux® and Enterprise Linux® are registered trademarks of Red Hat, Inc. in the United States and/or other countries. Novell® is a registered trademark and SUSE™ is a trademark of Novell Inc. in the United States and other countries. Oracle® is a registered trademark of Oracle Corporation and/or its affiliates. Citrix®, Xen®, XenServer® and XenMotion® are either registered trademarks or trademarks of Citrix Systems, Inc. in the United States and/or other countries. VMware®, Virtual SMP®, vMotion®, vCenter®, and vSphere® are registered trademarks or trademarks of VMWare, Inc. in the United States or other countries.

Other trademarks and trade names may be used in this publication to refer to either the entities claiming the marks and names or their products. Dell Inc. disclaims any proprietary interest in trademarks and trade names other than its own.

Contents

- 1 About this Guide
 - Related Publications 7

- 2 The S6000 System
 - Introduction 9
 - Features 10
 - Physical Dimensions 11
 - Chassis Ports 11
 - Determine System Status 11
 - LED Displays 11
 - Basic Installation Requirements 14
 - Orderable S6000 Components 15

- 3 Site Location and Preparation
 - Site Selection 18
 - Cabinet Placement 18
 - Rack Mount 18
 - Ground 18
 - Fans and Airflow 18
 - Fan Combinations 19
 - Power 19
 - Storing Components 19

- 4 Install the S6000
 - Unpack the S6000 System 21
 - Package Contents 21
 - Unpacking Steps 22
 - Install Rack or Cabinet Hardware 22
 - Rack Mount Safety Considerations 22
 - Installing the Dell ReadyRails System 23
 - Configuring a Two-Post Flush-Mount 24
 - Configuring a Two-Post Center-Mount 25
 - Configure a Four-Post Thread 26
 - Installing the S6000 System 27
 - Installing a 1U Front-Rack 27
 - Attaching the Ground Cable 28
 - Installing an AC or DC Power Supply 29
 - Installing QSFP+ Optics 31
 - Remove QSFP+ Optics 31





Split QSFP+ Ports to SFP+ Ports	31
Important Points to Know:	31
Power Up the S6000 System	32
Power Up Sequence	32
5 Power Supplies	
Components	33
Installing an AC or DC Power Supply	34
Replacing an AC or DC Power Supply	35
Connecting a DC Power Supply to the Power Source	35
Removing Power Connector from an S6000 DC Power Supply	36
6 Fans	
Components	37
Installing a Fan Module	38
Replacing a Fan Module	38
7 Management Ports	
Accessing the RS-232 Console Port.	39
Accessing the USB-B Console Port	40
Default Configuration	41
8 Specifications	
Chassis Physical Design.	43
Environmental Parameters	43
Power Requirements.	44
AC Input Specification	44
DC Input Specification.	44
IEEE Standards.	44
Agency Compliance	45
Network Equipment Building Systems (NEBS) Compliance	45
USA Federal Communications Commission (FCC) Statement	45
Canadian Department of Communication Statement	46
European Union EMC Directive Conformance Statement.	46
Japan: VCCI Compliance for Class A Equipment	46
Korean Certification of Compliance	47
Safety Standards and Compliance Agency Certifications	47
Electromagnetic Compatibility (EMC)	48
Product Recycling and Disposal	48
9 Technical Support	

The iSupport Website 51
 Accessing iSupport Services 51
Contacting the Technical Assistance Center 52
Requesting a Hardware Replacement 53

About this Guide

This guide provides site preparation recommendations, step-by-step procedures for rack mounting and desk mounting, and connecting to a power source.

After you have completed the hardware installation and power-up of the S6000, for software configuration information, refer to the *FTOS Configuration Guide for the S6000 System* and for Command line interface (CLI) information, refer to the *FTOS Command Line Reference Guide for the S6000 System*.

-  **NOTE:** For information about upgrading the S6000 system, refer to the *FTOS Release Notes for the S6000 System*. If you have any questions regarding FTOS versions and system upgrades, contact Dell Technical Support.
-  **CAUTION:** To avoid electrostatic discharge (ESD) damage, wear grounding wrist straps when handling this equipment.
-  **WARNING:** Only trained and qualified personnel can install this equipment. Read this guide before you install and power up this equipment. This equipment contains two power cords. Disconnect both power cords before servicing.
-  **WARNING:** This equipment contains optical transceivers, which comply with the limits of Class 1 laser radiation.

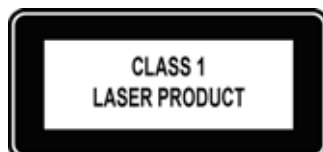

-  **WARNING:** When no cable is connected, visible and invisible laser radiation may be emitted from the aperture of the optical transceiver ports. Avoid exposure to laser radiation and do not stare into open apertures.

Related Publications

For more information about the S6000 system, refer to the following documents:

- *FTOS Configuration Guide for the S6000 System*
 - *FTOS Command Line Reference Guide for the S6000 System*
 - *FTOS Release Notes for the S6000 System*
-  **NOTE:** For the most recent documentation and software, visit iSupport (registration for access to some sections is required): <http://www.dell.com/support/manuals>.

The S6000 System

This chapter contains general features, capabilities, and physical configurations the S6000 supports.

Introduction

The S6000 is a fully featured switch/router one rack unit (RU) system that you can deploy as a spine, leaf, or top of rack (ToR) device where you require 10Gb and/or 40Gb connections. It contains 32 ports of 40G that you can use to create a configuration of 96 ports of 10G small form-factor pluggable plus (SFP+) (using breakout cables) and eight ports of 40G quad small form-factor pluggable (QSFP). The S6000 power supply unit (PSU) side ([Figure 2-1](#)) contains the PSU and fan modules.

Figure 2-1. S6000 PSU-Side View

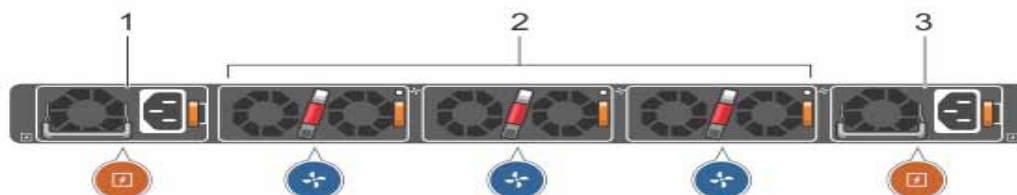

1 - PSU 0

2 - Fan Modules 0-2

3 - PSU 1

The S6000 input/output (I/O) side ([Figure 2-2](#)) includes:

- Thirty-two fixed QSFP+ ports
- One USB 2.0 port
- One USB-B serial console port
- One RS-232 serial console port
- One 10/100/1000BaseT (RJ-45) Ethernet management port

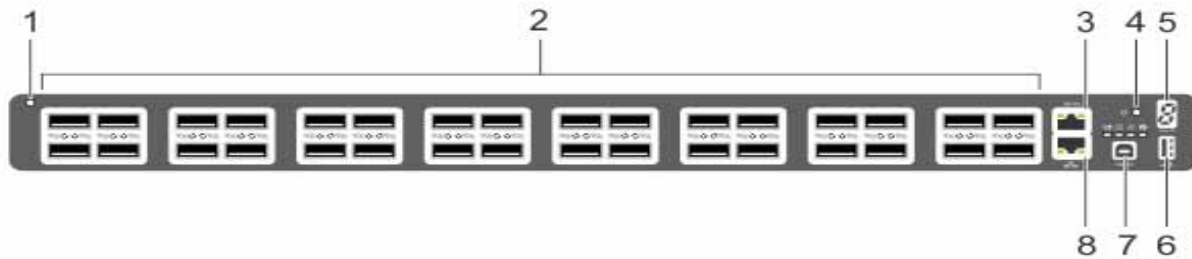
Figure 2-2. S6000 I/O-Side View

- 1 - System LED
- 2 - 32 QSFP+ Ports
- 3 - Serial Console
- 4 - Reset
- 5 - Stack ID
- 6 - USB-A
- 7 - USB-B Console
- 8 - Management

NOTE: The system light emitting diodes (LEDs) are on the I/O side. The fan tray power indicators are on the PSU side.

The S6000 system runs the Dell Networking operating system (FTOS), providing switching, bridging, and routing functionality for transmitting data, storage, and server traffic.

In a data center network, the S6000 system provides converged network support and inter-operates with Dell and third-party network devices. The switch supports data center bridging (DCB) features and optimizes connectivity between servers using Fibre Channel over Ethernet (FCoE) and internet small computer system interface (iSCSI) links.

By providing increased 40GbE bandwidth for device interconnection in a shared network storage environment (with the possibility of splitting 40GbE QSFP+ uplinks into four 10GbE SFP+ connections), the S6000 system is perfectly positioned to help transition a data center with multiple speed requirements.

Features

The S6000 has the following features:

- One universal serial bus (USB-A) port
- One USB-B console port
- Thirty-two 40Gbps QSFP ports for 40Gbps transceivers
- On-board high-performance central processing unit (CPU) system with large memory

- Temperature monitoring
- Software-readable thermal monitor
- Real time clock (RTC) support
- Hot-plugging redundant power supply
- Current monitoring for power management
- Removable fan that you can manage
- Standard 1U chassis high

Physical Dimensions

The S6000 has the following physical dimensions:

- 434 x 460 x 43.5 mm (W x D x H)
- 17.09 x 18.11 x 1.71 inches (W x D x H)

Chassis Ports

The following is a list of the standard ports located on each S6000 chassis:

- Serial RS-232 port (RJ-45 type)
- Out of band (OOB) Ethernet management port (RJ-45 type)
- Thirty-two 40Gbps QSFP+ ports
- One universal serial bus port (USB Type-A)

Determine System Status

You can view S6000 status information in several ways, including LEDs and boot menu options. Also, you can view status information through the CLI **show** commands and with simple network management protocol (SNMP) traps. For more information about these options, refer to the *FTOS Command Line Reference Guide for the S6000 System* and the *FTOS Configuration Guide for the S6000 System*.

LED Displays

As shown in [Figure 2-3](#), the S6000 includes LED displays on both the I/O and PSU side of the chassis. [Table 2-1](#) through [Table 2-3](#) list the LED definitions for the S6000 system. This includes the system, PSU, and fan status.

Figure 2-3. PSU and Fan Tray LEDs

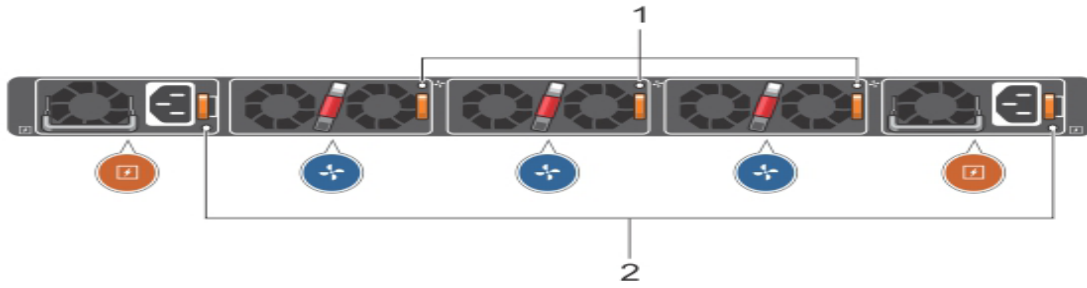

1- Fan Tray 0-2 LEDs

2 - PSU 0-1 LEDs

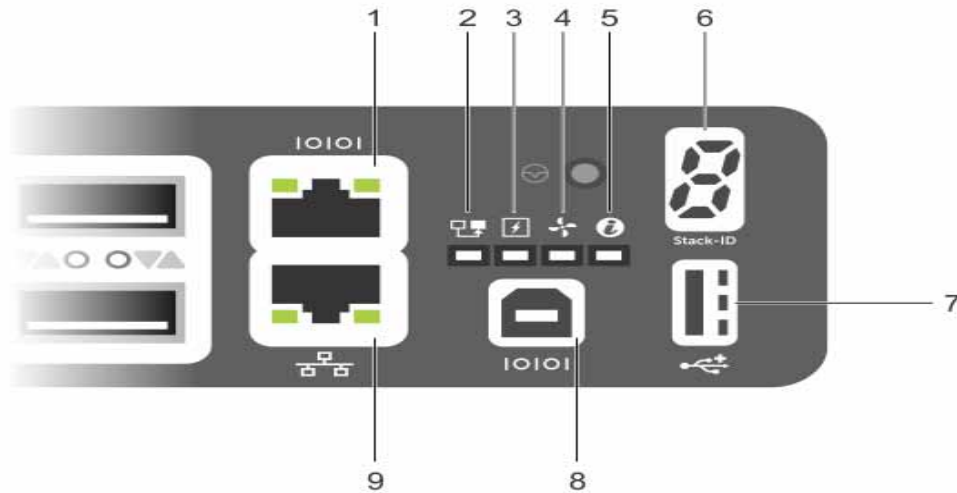

1 - Serial Console

2 - Master LED

3 - Power LED

4 - Fan Status LED

5 - Locator LED

6 - Stack ID

7 - USB-A

8 - USB-B Console

9 - Management

Table 2-1. System LED Displays

Feature	Detailed Description	Comment
System LED	<ul style="list-style-type: none"> • Solid green — Normal operation. The CLI prompt is available. • Blinking green — Boot-up in progress. • Solid yellow — Major Fault. Displays summary of all major faults within the system; the faults affect traffic. • Blinking yellow — Minor Fault. Displays summary of all minor faults within the system; the faults do not affect traffic. 	I/O side
Power LED	<ul style="list-style-type: none"> • Off — No power. • Solid Yellow — POST in progress. • Solid green — Normal operation (dual or single supply). • Blinking yellow — One of the power supplies has failed. 	I/O side
FAN LED	<ul style="list-style-type: none"> • Solid green — Fan powered and running at the expected rpm. • Solid yellow — Fan failed including incompatible airflow direction when PSU or fan trays of differing airflows are inserted in the same chassis. 	I/O side
MASTER LED	<ul style="list-style-type: none"> • Solid green — System in stacking Master mode. • Off — Switch in Slave mode. 	I/O side
LOCATOR LED	<ul style="list-style-type: none"> • Off — No power. • Blinking blue — Locator function is enabled. • Off — Locator function is disabled. 	I/O side
7-DIGIT Stack LED	<ul style="list-style-type: none"> • Indicates a number for stacking. 	I/O side

 **NOTE:** When one of the FAN LEDs on the utility side indicates failure, the fan LED on the I/O panel displays yellow.

The S6000 supports splitting a single 40G QSFP+ port into four 10G SFP+ ports using one of the supported breakout cables. This splitting is not allowed on ports 4, 12, 20, 28, 100, 108, 116, and 124. When you use the fanout feature, the 40G QSFP+ port is deleted and four 10G SFP+ ports are created.

QSFP+ ports have eight LEDs associated with each stack of two ports; four for the top and four for the bottom ports. You can configure each port as a single 40G port or four 10G ports. When configured as a 40G port, only the first of the four LEDs is used. When configured as four 10G ports, all four LEDs are used to indicate the status. [Table 2-2](#) lists the LED status and [Table 2-3](#) lists the management port LED status.

Table 2-2. 40G QSFP+/ 4x10G SFP+ Ethernet Port LEDs

Feature	Detailed Description
Link/Activity LED	<ul style="list-style-type: none"> • Off — No Link. • Blinking green — Transmit/Receive is active. • Solid green — Link up at 40Gbps/10Gbps speed.

Table 2-3. Management Ethernet Port LEDs

Feature	Detailed Description
Link LED	<ul style="list-style-type: none"> • Off — No Link. • Solid green — Link on 10/100M/1G speed.
Activity LED	<ul style="list-style-type: none"> • Off — No Link. • Blinking green — Transmit/Receive is active.

Basic Installation Requirements

Detailed installation instructions for the S6000 are provided in [Chapter 3, Site Location and Preparation](#) and [Chapter 4, Install the S6000](#). However, here is an initial list of components required for a successful installation of the S6000:

- S6000 chassis
- If you ordered AC units, cables to connect the AC power source to each of the chassis' AC power supplies (country/regional configured)
- If you ordered DC units, cables to connect the DC power source to each of the chassis' DC power supplies
- Mounting brackets for rack installation (included)
- Screws for rack installation and #1 and #2 Phillips screwdrivers (not included)
- Ground cable (not included)
- Ground cable screws (included)
- Copper/fiber cables

Optional components for installation:

- Additional power supply units
- Additional fan modules
- Additional mounting brackets (if installing in a 4-post rack or cabinet)

Orderable S6000 Components

You can order the S6000 system in several different configurations. Also, you can order optional modules and optics separately.

The following is a list of different configurations and modules:

- S6000 AC Normal Airflow: 32 40Gbps QSFP+ ports, 2 AC power supply and 3 fan subsystems (airflow from the I/O side to the PSU side)
- S6000 AC Reverse Airflow: 32 40Gbps QSFP+ ports, 2 AC power supply and 3 fan subsystems (airflow from the PSU side to the I/O side)
- S6000 AC Normal Airflow: 32 40Gbps QSFP+ ports, 2 DC power supply and 3 fan subsystems (airflow from the I/O side to the PSU side)
- S6000 AC Reverse Airflow: 32 40Gbps QSFP+ ports, 2 DC power supply and 3 fan subsystems (airflow from the PSU side to the I/O side)
- Fan with airflow from the I/O side to the PSU side
- Fan with airflow from the PSU side to the I/O side
- AC Power supply with airflow from the I/O side to the PSU side
- AC Power supply with airflow from the PSU side to the I/O side
- DC Power supply with airflow from the I/O side to the PSU side
- DC Power supply with airflow from the PSU side to the I/O side

Site Location and Preparation

The S6000 is suitable for installation as part of a common bond network (CBN). It can be installed in:

- Network telecommunication facilities
- Data centers
- Other locations where the national electric code (NEC) applies

This chapter contains the following sections regarding where and how you should install the S6000:

- [Site Selection](#)
- [Cabinet Placement](#)
- [Rack Mount](#)
- [Ground](#)
- [Fans and Airflow](#)
- [Power](#)
- [Storing Components](#)

 **NOTE:** Install the S6000 system into a rack or cabinet before installing any optional components.

Site Selection

Dell Network's equipment is intended for installation in restricted access areas. A restricted access area is one in which access can only be gained by service personnel through the use of a special tool, lock, key, or other means of security and access is controlled by the authority responsible for the location.

Ensure that the area where the S6000 system is installed meets the following safety requirements:

- Near an adequate power source. Connect the system to the appropriate branch circuit protection as defined by your local electrical codes.
- Environmental temperature between 32° to 113°F (0° to 45°C).
- Relative humidity that does not exceed 90% non-condensing.
- In a dry, clean, well-ventilated and temperature-controlled room, away from heat sources such as hot air vents or direct sunlight.
- Away from sources of severe electromagnetic noise.
- Positioned in a rack or cabinet, or on a desktop with adequate space in the front, rear, and sides of the S6000 for proper ventilation and access.

Cabinet Placement

Install the S6000 only in indoor cabinets designed for use in a controlled environment as described in [Site Selection](#). Do not install the S6000 in outside plant cabinets.

The cabinet must meet the following:

- Minimum cabinet size and airflow are according to the Electronic Industries Alliance (EIA) standard.

Rack Mount

When you prepare your equipment rack, ensure that the rack is earth ground. Ground the equipment rack to the same ground point used by the power service in your area. The ground path must be permanent.

Ground

Use the S6000 in a CBN. Connect the grounding cables as described in [Chapter 4, Install the S6000](#).

Fans and Airflow

The S6000 fans support two airflow options. Be sure to order the fans suitable to support your site's ventilation. Use a single type of airflow fan in your system. Do not mix reverse and normal airflows in a single S6000 chassis.

Fan Combinations

The S6000 has stock keeping units (SKUs) that support the following configurations. Installation of the fans is done as part of the factory install based on SKU type.

- AC PSU with fan airflow from I/O to PSU
- AC PSU with fan airflow from PSU to I/O
- DC PSU with fan airflow from I/O to PSU
- DC PSU with fan airflow from PSU to I/O

All fans and PSUs in a configuration must be in the same airflow direction. Should a mixed airflow configuration happen, the software notifies you of the invalid configuration.

The S6000 supports three fan trays with airflow directions from the I/O to the utility or the utility to the I/O.

For proper ventilation, position the S6000 in an equipment rack (or cabinet) with a minimum of five inches (12.7cm) of clearance around the exhaust vents. When you install two S6000 systems near each other, position the two chassis at least five inches (12.7cm) apart to permit proper airflow. The fan speed increases when the internal temperature reaches 72°C and decreases to normal speed when the temperature falls to 58°C. The S6000 never intentionally turns off the fans.

To see the log messages, use the **show logging** command. For more information, refer to the System Logs chapters of the *FTOS Command Line Reference Guide for the S6000 System* and *FTOS Configuration Guide for the S6000 System*.

Power

To connect the chassis to the applicable power source, use the appropriate power cord with the S6000 system.

- If the switch is an AC model, an AC power cord (country/region specific) is included with the system.
- If the switch is a DC model, a DC power cord (country/region specific) is included with the system.

When installing AC systems, follow the requirements of the National Electrical Code, ANSI/NFPA 70 where applicable.

The system is powered-up as soon as the power cord is connected between the system and the power source.

 **CAUTION:** Always disconnect the power cable before you service the power supply slots.

 **CAUTION:** Use the power supply cord as the main disconnect device on the AC system. Make sure that the socket-outlet is located/installed near the equipment and is easily accessible.

Storing Components

If you do not install your S6000 and components immediately, Dell Networking recommends properly storing the system and all optional components until you are ready to install them.

Follow these storage guidelines:

- Storage temperature must remain constant ranging from -4° to 158° F (-20°C to 70° C).
- Store on a dry surface or floor, away from direct sunlight, heat, and air conditioning ducts.
- Store in a dust-free environment.

 **WARNING:** ESD damage can occur when components are mishandled. Always wear an ESD-preventive wrist or heel ground strap when handling the S6000 and its accessories. After you remove the original packaging, place the S6000 and its components on an anti-static surface.

Install the S6000

To install the S6000 system, Dell Networking recommends completing the installation procedures in the order presented in this chapter.

Always handle the S6000 and its components with care. Avoid dropping the system or its field replaceable units (FRUs).

This chapter describes the installation procedures as follows:

- [Unpack the S6000 System](#)
- [Install Rack or Cabinet Hardware](#)
 - [Installing the Dell ReadyRails System](#)
 - [Configuring a Two-Post Flush-Mount](#)
 - [Configuring a Two-Post Center-Mount](#)
 - [Configure a Four-Post Thread](#)
- [Installing the S6000 System](#)
 - [Installing a 1U Front-Rack](#)
 - [Attaching the Ground Cable](#)
 - [Installing an AC or DC Power Supply](#)
- [Installing QSFP+ Optics](#)
- [Power Up the S6000 System](#)

 **WARNING:** ESD damage can occur if components are mishandled. Always wear an ESD-preventive wrist or heel ground strap when handling the S6000 and its components. As with all electrical devices of this type, take all the necessary safety precautions to prevent injury when installing this system.

Unpack the S6000 System

 **NOTE:** Before unpacking the system, inspect the container and immediately report any evidence of damage.

Package Contents

When unpacking each S6000 system, make sure that the following items are included:

- One S6000 system
- One RJ-45 to DB-9 female cable
- Two sets of rail kits (no tools required)
- Two PSUs

- If an AC switch, at least one AC power cord (country/region specific)
- If a DC switch, at least one DC power cable
- *Getting Started Guide*
- *Safety and Regulatory Information*
- *Warranty and Support Information*
- *Software License Agreement*

Unpacking Steps

- 1 Place the container on a clean, flat surface and cut all straps securing the container.
- 2 Open the container or remove the container top.
- 3 Carefully remove the switch from the container and place it on a secure and clean surface.
- 4 Remove all packing material.
- 5 Inspect the product and accessories for damage.

Install Rack or Cabinet Hardware

You may either place the switch on the rack shelf or mount the switch directly into a 19" wide, EIA-310-E-compliant rack (four-post, two-post, or threaded methods). The Dell ReadyRails™ system is provided for one 1U front-rack and two-post installations. The ReadyRails system includes two separately packaged rail assemblies and two rails that are shipped attached to the sides of the switch.

 **WARNING:** This is a condensed reference. Read the safety instructions in your Safety, Environmental, and Regulatory information booklet before you begin.

 **NOTE:** The illustrations in this document are not intended to represent a specific switch.

 **NOTE:** Do not use the mounted Ready-Rails as a shelf or a workplace.

Rack Mount Safety Considerations

- **Rack loading** — Overloading or uneven loading of racks may result in shelf or rack failure, causing damage to the equipment and possible personal injury. Stabilize racks in a permanent location before loading begins. Mount the components beginning at the bottom of the rack, then work to the top. Do not exceed your rack load rating.
- **Power considerations** — Connect only to the power source specified on the unit. When multiple electrical components are installed in a rack, ensure that the total component power ratings do not exceed the circuit capabilities. Overloaded power sources and extension cords present fire and shock hazards.
- **Elevated ambient temperature** — If installed in a closed rack assembly, the operating temperature of the rack environment may be greater than the room ambient temperature. Use care not to exceed the 40°C maximum ambient temperature of the switch.

- Reduced air flow — Install the equipment in the rack so that the amount of airflow required for safe operation of the equipment is not compromised.
- Reliable earthing — Maintain reliable earthing of rack-mounted equipment. Pay particular attention to the supply connections other than the direct connections to the branch circuit, for example: use of power strips.
- Do not mount the equipment with the rear panel facing in the downward position.

Installing the Dell ReadyRails System

The ReadyRails rack mounting system is provided to easily configure your rack for installation of your S6000 system. You can install the ReadyRails system using the 1U tool-less method or one of three possible 1U tool-ed methods (two-post flush mount, two-post center mount, or four-post threaded).

Step	Task
1	With the ReadyRails flange ears facing outward, place one rail between the left and right vertical posts. Align and seat the rear flange rail pegs in the rear vertical post flange. In Figure 4-1 , item 1 and its extractions show how the pegs appear in both the square and non-threaded round holes.

Figure 4-1. 1U Tool-less Configuration

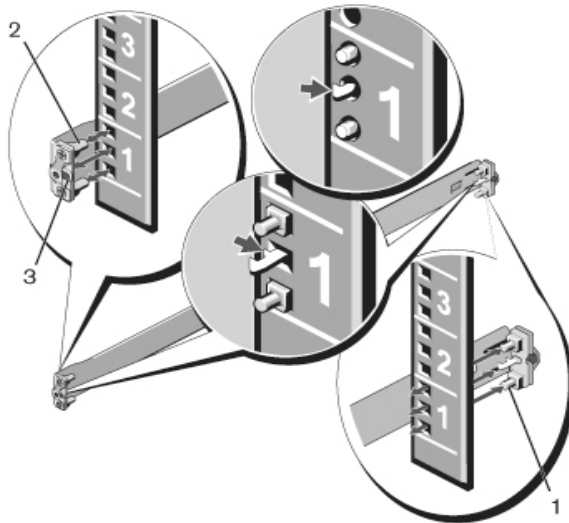

2	Align and seat the front flange pegs in the holes on the front side of the vertical post. Refer to Figure 4-1 , item 2.
3	Repeat this procedure for the second rail.
4	To remove each rail, pull on the latch release button on each flange ear and unseat each rail. Refer to Figure 4-1 , item 3.

Configuring a Two-Post Flush-Mount

Step	Task
1	For this configuration, remove the castings from the front side of each ReadyRails assembly. Refer to Figure 4-2 , item 1. To remove the two screws from each front flange ear (on the switch side of the rail) and remove each casting, use a Torx driver. Retain the castings for future rack requirements. It is not necessary to remove the rear flange castings.

Figure 4-2. Two-Post Flush-Mount Configuration

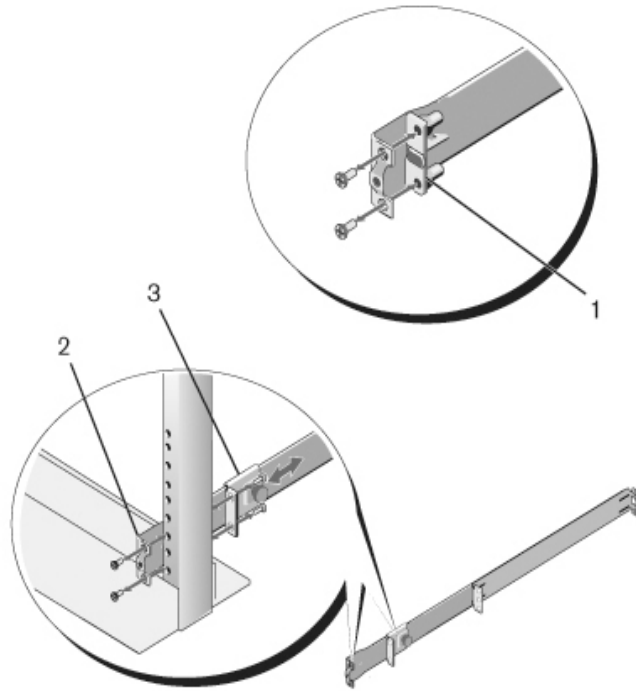

2	Attach one rail to the front post flange with two user-supplied screws. Refer to Figure 4-2 , item 2.
3	Slide the plunger bracket forward against the vertical post and secure the plunger bracket to the post flange with two user-supplied screws. Refer to Figure 4-2 , item 3.
4	Repeat this procedure for the second rail.

Configuring a Two-Post Center-Mount

Step	Task
1	Slide the plunger bracket rearward until it clicks into place and secure the bracket to the front post flange with two user-supplied screws. Refer to Figure 4-3 , item 1.

Figure 4-3. Two-Post Center-Mount Configuration

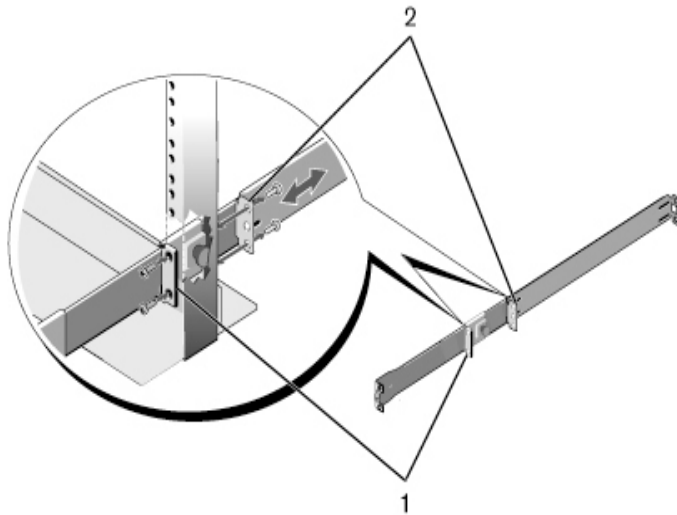

2	Slide the back bracket towards the post and secure it to the post flange with two user-supplied screws. Refer to Figure 4-3 , item 2.
3	Repeat this procedure for the second rail.

Configure a Four-Post Thread

Step	Task
1	For this configuration, remove the flange ear castings from each end of the ReadyRails assemblies. To remove the two screws from each flange ear and remove each casting, use a Torx driver. Refer to Figure , item 1. Retain the castings for future rack requirements.
2	For each rail, attach the front and rear flanges to the post flanges with two user-supplied screws at each end. Refer to Figure , item 2.

Figure 4-4. Four-Post Threaded Configuration

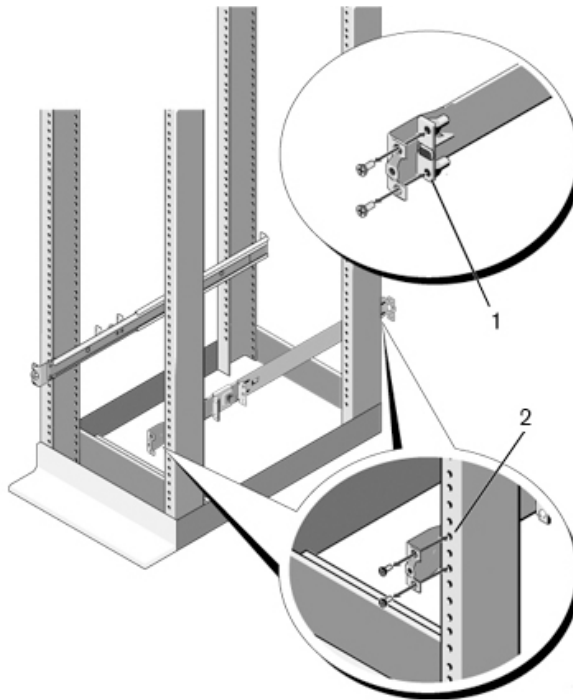

Installing the S6000 System

You can mount the system in the 1U front-rack or 1U two-post (flush and center) configurations. The following is an example of a front-rack configuration. For the 1U two-post (flush and center) configurations, slide the system into the rails in the same manner as the four-post configurations.

Installing a 1U Front-Rack

You must configure the rails that are attached to the system.

Step	Task
1	Attach the switch rails (inner chassis members) to the S6000 system. Figure 4-5 , item 3 shows the detail for the front standoff with the locking tab.

Figure 4-5. Attaching the Switch Rails

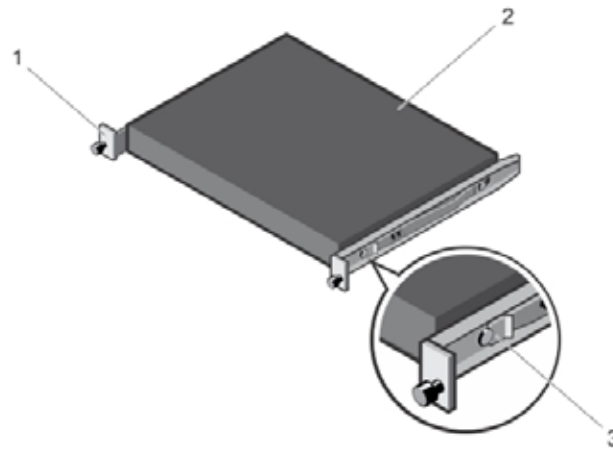

Step	Task
2	After you have installed both switch rails, line them up on the previously mounted Ready-Rails and slide the switch in until it is flush with front of rack. About three inches prior to full insertion, the rail locking feature engages to keep the switch from inadvertently sliding out of the rack and falling.

NOTE: Do not use the mounted Ready-Rails as a shelf or a workplace.

Figure 4-6. Front Rack Installation

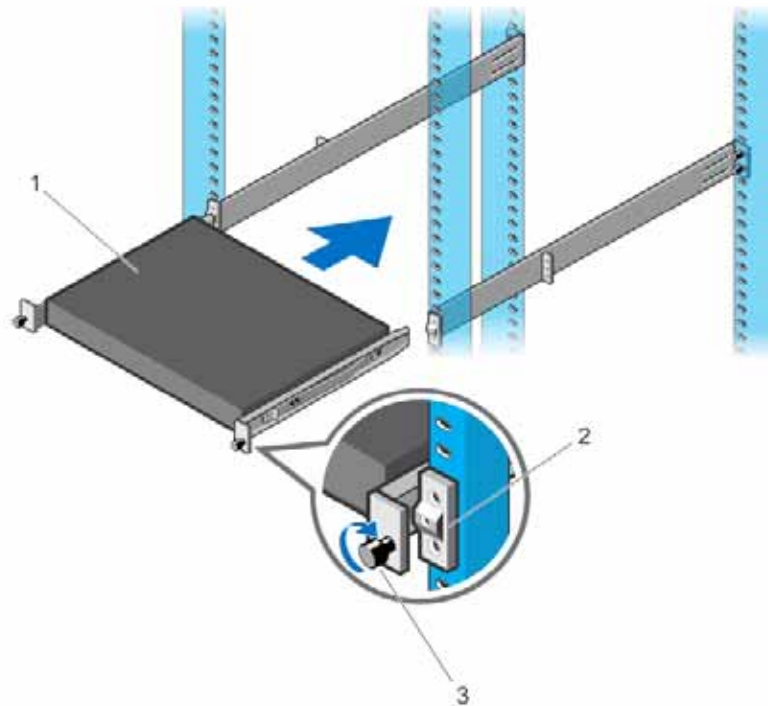

Attaching the Ground Cable

To attach the ground cable to the chassis, use a single M4x0.7 screw. The cable itself is not included with the S6000. To properly ground the chassis, Dell Networking recommends using a 6AWG one-hole lug, #10 hole size, 63" spacing (not included in shipping). The one-hole lug must be a UL recognized, crimp-type lug.

To connect the ground cable to the system, follow these steps:

- CAUTION:** Grounding conductors *must* be made of copper. Do not use aluminum conductors.
- NOTE:** The rack installation “ears” are not suitable for grounding.
- NOTE:** Coat the one-hole lug with an anti-oxidant compound prior to crimping. Also, bring any un-plated mating surfaces to a shiny finish and coat with an anti-oxidant prior to mating. Plated mating surfaces must be clean and free from contamination.

Step	Task
1	Take the one M4x0.7 screw from the package.

Step	Task
2	Cut the cable to the desired length. The cable length must facilitate proper operation of the fault interrupt circuits. Dell Networking recommends using of the shortest cable route allowable.
3	Attach the one-hole lug to the chassis using the supplied 10-32 screw with the captive internal tooth lock washer. Torque the screw to 20 in-lbs.
4	Attach the other end of the ground cable to a suitable ground point. The rack installation ears are not a suitable grounding point.

Installing an AC or DC Power Supply

The S6000 supports two hot-swappable PSUs with integrated fans that provide cooling for the system. The S6000 supports AC and DC power supplies with two air-flow directions (I/O to PSU or PSU to I/O). Two PSUs are required for full redundancy, but the system will operate with a single PSU.

NOTE: S6000 ships with two PSUs. However, it is possible to run the unit with a single PSU. If you use a single PSU, install a blank plate in the other PSU slot. Dell Networking recommends using power supply 1 (PSU1) as the blank plate slot.

The PSUs are field replaceable. When running with full redundancy (two power supplies installed and running), you can remove and replace one PSU while the other PSU is running without disrupting traffic.

The S6000 does not support mixing PSU types. You cannot replace an AC PSU with a DC PSU and you cannot replace an AC-R PSU with a DC-R PSU.

WARNING: ESD damage can occur if components are mishandled. Always wear an ESD-preventive wrist or heel ground strap when handling the S6000 and its components.

CAUTION: To prevent electrical shock, ensure the S6000 is grounded properly. If you do not ground your equipment correctly, excessive emissions may result. Use a qualified electrician to ensure the power cables meet your local electrical requirements.

Figure 4-7. S6000 Power Supply

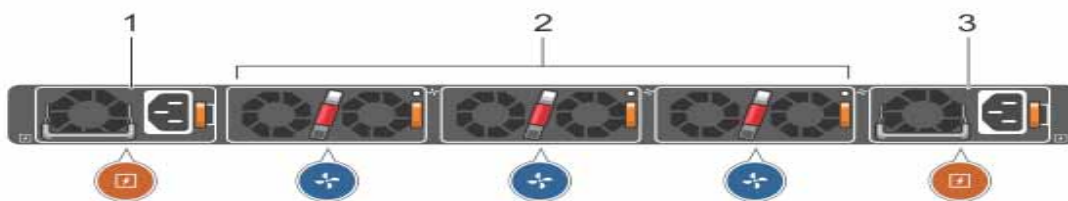

1 - PSU 0

3 - PSU 1

NOTE: The PSU slides into the slot smoothly. Do not force a PSU into a slot as this may damage the PSU or the S6000 chassis.

NOTE: Ensure that the PSU is correctly installed. When the PSU is correctly installed, the power connector is on the right side of the PSU and the status LED is at the bottom of the PSU.

- NOTE:** S6000 ships with two PSUs. However, it is possible to run the unit with a single PSU. If you use a single PSU, install a blank plate in the other PSU slot. Dell Networking recommends using power supply 1 (PSU1) as the blank plate slot.

To install an AC or DC power supply, follow these steps:

Step	Task
1	Remove the PSU slot cover from the S6000 (PSU side of switch), either of the two PSU slots may be selected.
2	Remove the PSU from the electrostatic bag.
3	Insert the PSU into the switch PSU slot (insert the PSU-exposed PCB edge connector first). The PSU slot is keyed such that the PSU can only be fully inserted in one orientation.

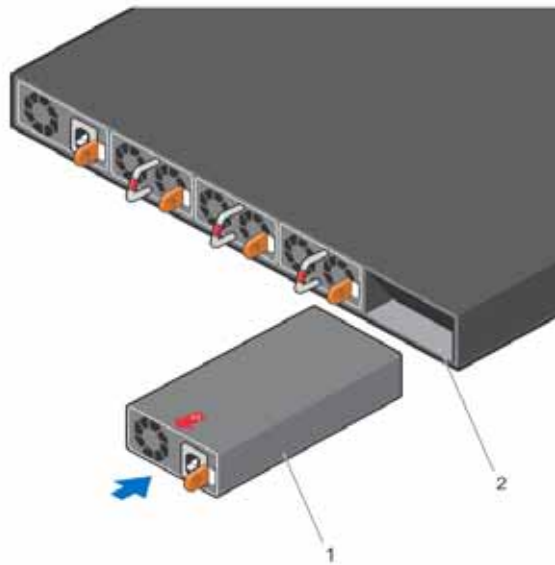

- 1 - Slot 1
2 - PSU 1

When you install the PSU correctly it should snap into place and be flush with the back of the switch.

4	Plug in the appropriate cord (AC 3 prong or DC wiring) from the switch PSU to the external power source (either AC wall outlet or DC rack bus bar).
5	If you have a redundant PSU (2nd PSU), repeat steps 1 through 5 above using the 2nd PSU slot on the S6000 system.

- NOTE:** The system powers up as soon as the cables are connected between the power supply and the power source.

Installing QSFP+ Optics

The S6000 has 32 40Gbps QSFP+ optical ports.

 **WARNING:** ESD damage can occur if components are mishandled. Always wear an ESD-preventive wrist or heel ground strap when handling the S6000 and its components.

 **WARNING:** When working with optical fibers, follow all warning labels and always wear eye protection. Never look directly into the end of a terminated or unterminated fiber or connector, which may cause eye damage.

To install QSFP+ optics into an open port, follow these steps:

- 1 Position the optic so it is in the correct position. The optic has a key that prevents it from being inserted incorrectly.
- 2 Insert the optic into the port until it gently snaps into place.

LR4 optics can be installed only on top row front end ports 4, 12, 20, 28, 36, 44, 52, 60, 68, 76, 84, 92, 100, 108, 116, and 124.

 **NOTE:** Both rows of QSFP+ ports require that you insert the 40G optics with the tabs facing up.

Remove QSFP+ Optics

Remove an optic by pushing the tab on the optic and sliding the optic from the port.

When removing optics with direct attach cables (DACs) from the port, pull the release tab firmly and steadily. Prior to pulling the release tab, you may need to gently push the optic into the port to ensure it is seated properly. Do not jerk or tug repeatedly on the tab.

Split QSFP+ Ports to SFP+ Ports

The S6000 supports splitting a single 40G QSFP+ port into four 10G SFP+ ports using one of the supported breakout cables. This splitting is not allowed on ports 4, 12, 20, 28, 100, 108, 116, and 124. When you use the fanout feature, the 40G QSFP+ port is deleted and four 10G SFP+ ports are created.

For the system to recognize the port type change, enter the **stack-unit portmode** command.

For example:

```
stack-unit stack-unit port number portmode quad
```

- *stack-unit*: Enter the stack member unit identifier of the stack member to reset. The range is from 0 to 5.
- *number*: Enter the port number of the 40G port to be split. The range is from 0 to 124.

Important Points to Know:

- The unit number with the split ports must be the default (stack-unit 0). You can verify this using the **show system brief** command.
- The quad port must be in a default configuration before you can split it into four 10G ports. The 40G port is lost in the configuration when you split the port, so be sure that the port is also removed from other L2/L3 feature configurations.

- For the split-port change to take effect, you must reload the system after issuing the command. Save your configuration.

Power Up the S6000 System

Supply power to the S6000 after it is mounted in a rack or cabinet.

Dell Networking recommends re-inspecting your system prior to powering up. Verify that the:

- equipment is properly secured to the rack and properly grounded.
- equipment rack is properly mounted and grounded.
- ambient temperature around the unit (which may be higher than the room temperature) is within the limits specified for the S6000.
- airflow around the S6000 unit is sufficient.
- input circuits are correctly sized for the loads and that you are using sufficient over-current protection devices.
- protective covers on the S6000 are in place.
- blank panels are installed over all openings in the S6000 chassis that would have contained optional modules.

Power Up Sequence

When the system powers up, the fans immediately come on at high speed. The fan speed slows as the system continues to boot up.

The PWR LED blinks until the boot-up sequence is complete. When boot up is complete, the PWR LED becomes steadily lit.

Power Supplies

The S6000 supports two hot-swappable PSUs with integrated fans that provide cooling for the system. The S6000 supports AC and DC power supplies with two air-flow directions (I/O to PSU and PSU to I/O). Two PSUs are required for full redundancy, but the system will operate with a single PSU.

NOTE: If you use a single PSU, install a blank plate in the other PSU slot. Dell Networking recommends using power supply 1 (PSU1) as the blank plate slot.

The PSUs are field replaceable. When running with full redundancy (two power supplies installed and running), you can remove and replace one PSU without disrupting traffic.

The S6000 does not support mixing PSU types. You cannot replace an AC PSU with a DC PSU and you cannot replace an AC-R PSU with a DC-R PSU.

WARNING: ESD damage can occur if components are mishandled. Always wear an ESD-preventive wrist or heel ground strap when handling the S6000 and its components.

CAUTION: To prevent electrical shock, ensure the S6000 is grounded properly. If you do not ground your equipment correctly, excessive emissions may result. Use a qualified electrician to ensure the power cables meet your local electrical requirements.

Components

The following power supply options are available for the S6000:

- AC power supply with integrated fan
- AC power supply with integrated reverse flow fan
- DC power supply with integrated fan
- DC power supply with integrated reverse flow fan

Power supply 0 (PSU0) is on the left side of the chassis; power supply 1 (PSU1) is on the right side of the chassis.

Figure 5-1. S6000 with PSU

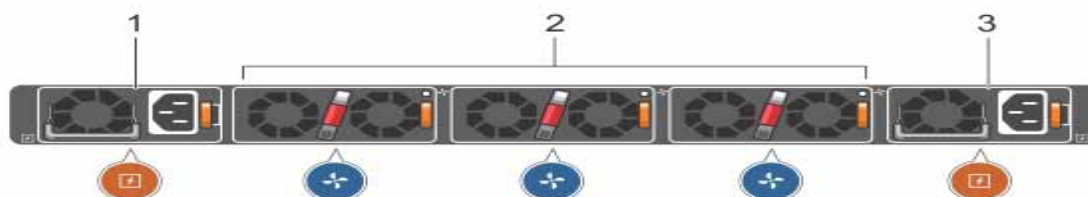

1 - PSU 0

2 - Fan Modules 0-2

3 - PSU 1

The PSUs are in a single piece with the PSU fans (see [Figure 5-1](#)). You can replace the fan trays individually, but you cannot replace the fans that are integrated in the PSUs—if the fans integrated in the PSU fail, you must replace the entire PSU. For fan tray replacement procedures, refer to [Chapter 6, Fans](#).

- ⚠ WARNING:** Prevent exposure and contact with hazardous voltages. Do not attempt to operate this system with the safety cover removed.
- ⚠ CAUTION:** Remove the power cable from the PSU prior to removing the PSU. Also, do not connect the power cable before you insert the PSU in the chassis.
- ⚠ CAUTION:** The DC PSU comes with a 6-8 inch power cord with a snap-in plug that attaches to the DC power supply and screw terminals that attach to the main power. To ensure sufficient room, Dell Networking recommends using a longer cable.
- ⚠ CAUTION:** The power supply is marked + 48V -. Connect the + (plus sign) to the red cable on the 6-8 inch cord; connect the - (minus sign) to the black cable on the 6-8 inch cord. **BE SURE TO** connect the RED cable to RETURN and the BLACK cable to -48V.
- 🔧 NOTE:** To comply with the GR-1089 Lightning Criteria for Equipment Interfacing with AC Power Ports, use an external SPD at the AC input of the router.

Installing an AC or DC Power Supply

To install an AC or DC power supply, follow these steps:

- 🔧 NOTE:** The PSU slides into the slot smoothly. Do not force a PSU into a slot as this may damage the PSU or the S6000 chassis.
- 🔧 NOTE:** Ensure that you correctly install the PSU. When you install the PSU correctly, the power connector is on the left side of the PSU and the status LED is at the bottom of the PSU.
- 🔧 NOTE:** If you use a single PSU, install a blank plate in the other PSU slot. Dell Networking recommends using power supply 1 (PSU1) as the blank plate slot.

Step	Task
1	Remove the PSU slot cover from the S6000 (the PSU side of switch). You may select either of the two PSU slots.
2	Remove the PSU from the electro-static bag.
3	Insert the PSU into the switch PSU slot (insert the PSU exposed PCB edge connector first). The PSU slot is keyed such that the PSU can only be fully inserted in one orientation.



1 - Slot 1

2 - PSU1

When you install the PSU correctly, it snaps into place and is flushed with the back of the switch.

Step	Task
4	Plug in the appropriate cord (AC 3 prong or DC wiring) from the switch PSU to the external power source (either an AC wall outlet or a DC rack bus bar).
5	If you have a redundant PSU (a second PSU), repeat steps 1 through 4 above using the second PSU slot on the S6000 system.

 **NOTE:** The S6000 powers up as soon as the cables are connected between the power supply and the power source.

Replacing an AC or DC Power Supply

 **Caution:** Disconnect power cord before removing power supplies and disconnect all power cords before servicing.

 **NOTE:** The PSU slides into the slot smoothly. Do not force a PSU into a slot as this may damage the PSU or the S6000 chassis.

 **NOTE:** If a PSU fails, you must completely replace it. There are no field servicable components in the PSU. To request a hardware replacement, refer to [Chapter 9, Technical Support](#).

 **NOTE:** If you use a single PSU, install a blank plate in the other PSU slot. Dell Networking recommends using power supply 1 (PSU1) as the blank plate slot.

To replace an AC or DC power supply, follow these steps:

Step	Task
1	Disconnect the power cable from the PSU.
2	Use the grab handle to slide the PSU out of the power supply bay.
3	Use the grab handle on the replacement PSU to slide the PSU into the power supply bay.
4	Attach the power cord to the replacement PSU.

 **WARNING:** The S6000 powers up as soon as the cables are connected between the power supply and the power source.

Connecting a DC Power Supply to the Power Source

Each DC powered S6000 comes with a set containing a pre-wired (3-inch 8AWG) power supply connector and a four-screw wiring block. One set is provided for each DC PSU (See [Figure 5-2](#)).

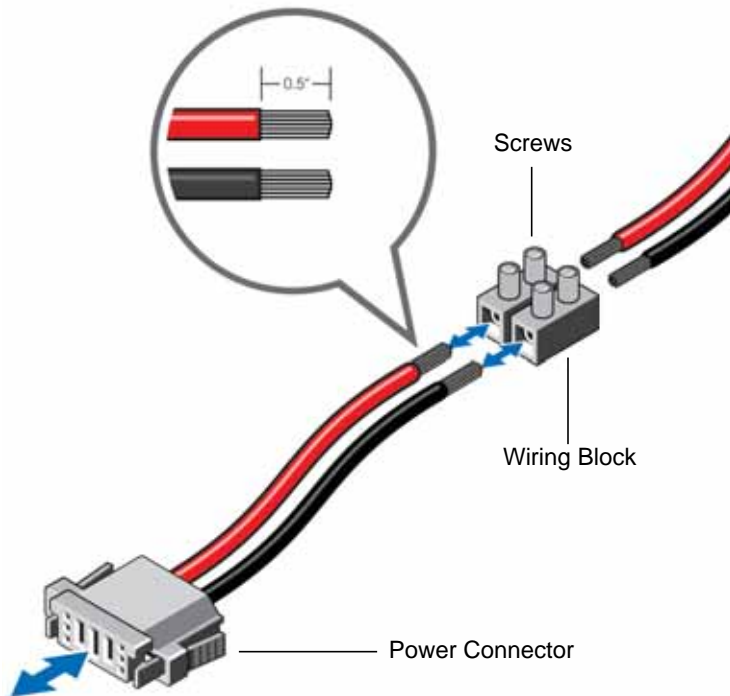
Figure 5-2. DC Power Connector and Wiring Block

To connect a S6000 DC PSU to the site's DC power source, follow these steps:

Step	Task
1	Strip 1/2" of insulation from each of the power connector's wires (red and black, See Figure 5-2).
2	Insert each of the power connector's bare wire lengths into the wiring block (See Figure 5-2). Red into one hole and black into the other hole.
3	Use a flat-blade screwdriver to tighten the screws, which secures the bare wires into the wiring block.
4	Secure the site's DC power source wires to the other side of the wiring block.
	⚠ WARNING: Make sure not to cross the wires—In the wiring block, red should align with red and black should align with black (See Figure 5-2).
5	Insert the DC power connector into the power socket of the S6000 DC PSU. Make sure that you feel the connector pins firmly seat and you hear the click of the power connector's left and right levered clamps lock into place.
	⚠ WARNING: Never try to force the power connector into or out of the DC PSU power socket.

Removing Power Connector from an S6000 DC Power Supply

To remove the power connector from an S6000 DC PSU, squeeze together the levers on both sides of the connector. Doing so disengages the power connector's clamps. While continuing to squeeze, pull the power connector from the DC PSU socket.

Fans

The S6000 comes from the factory with two PSUs and three fan modules installed in the chassis (see [Figure 6-1](#)). The S6000 has SKUs that support the following configurations. Installation of the fans is done as part of the factory install based on SKU type.

- AC PSU with fan airflow from I/O to PSU
- AC PSU with fan airflow from PSU to I/O
- DC PSU with fan airflow from I/O to PSU
- DC PSU with fan airflow from PSU to I/O

All fans and PSUs in a configuration must be in the same airflow direction. Should a mixed airflow configuration happen, the software notifies you of the invalid configuration.

The S6000 supports three fan trays with airflow directions from the I/O to the utility or the utility to the I/O.

Environmental factors can decrease the amount of time required between fan replacements. Check the environmental factors regularly. An increase in temperature and/or particulate matter in the air might affect performance (for example, new equipment installation).

CAUTION: Check the fans at six-month intervals and replace them as necessary. Regularly monitor the speeds of the cooling fans in order to accurately determine replacement intervals.

Components

- S6000 Fan module
- S6000 Fan module - Reverse flow

Figure 6-1. S6000 Fan Modules and PSU

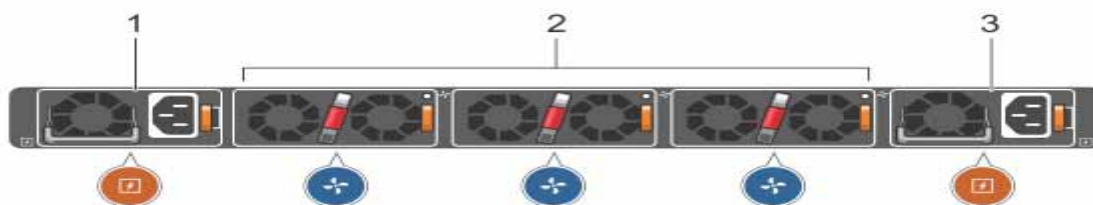

1 - PSU 0

2 - Fan Modules 0-2

3 - PSU 1

Installing a Fan Module



CAUTION: DO NOT mix airflow directions. All fans must use the same airflow direction (reverse or normal). If the airflows are mismatched, an error message appears and the system shuts down.

```
00:02:19:%S6000:0%CHMGR-2-PSU_TYPE_AIRFLOW_MISMATCH: Mismatching PSU airflow detected. Unit 0 shall get shutdown in next 60 seconds if mismatch not rectified.
```

```
00:02:19:%STKUNIT0-M:CP%CHMGR-1-PSU_AIRFLOW_COMBO_MISMATCH: Major alarm: Mismatching PSU airflow detected in unit 0
```

The fan modules in the S6000 are field replaceable. Module slot 0 is on the left side of the chassis; module slot 2 is on the right side of the chassis.

To install a fan module, follow these steps:

Step	Task
1	Take the fan module out of the shipping box.
2	Use the grab handle to slide the fan module into the bay.

Replacing a Fan Module

To replace a fan module, follow these steps:

Step	Task
	CAUTION: You must complete steps 1 and 2 within one minute or the system powers down.
1	Use the grab handle to slide the fan module out of the bay.
2	Use the grab handle on the replacement module to slide it into the bay.

Management Ports

Besides the 10 Gigabit and 40 Gigabit switch ports, the S6000 provides several ports for management and storage.

Accessing the RS-232 Console Port

- ✎ **NOTE:** Before starting this procedure, be sure that your PC has a 9-pin serial port and that you have a terminal emulation program already installed and running on the PC.
- ✎ **NOTE:** If your PC's serial port cannot accept a female DB-9 connector, acquire a DB-9 male-to-male adaptor. The RS-232 console port is located (and labeled) on the I/O-side of the S6000 chassis (see [Figure 7-1](#)).

Figure 7-1. Location of Console Port

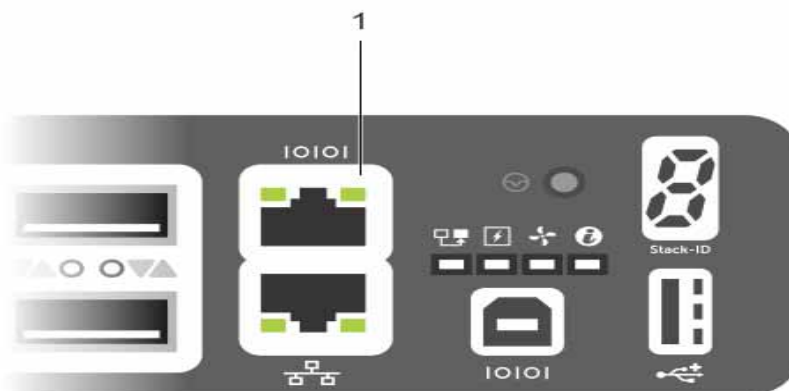

1 - RS-232 console port

To access the console port, follow these steps:

Step	Task
1	Install the provided RJ-45 connector side of the provided copper cable into the S6000 console port.
2	Install the DB-9 female side of the provided copper cable into your PC's serial port (or into other DTE terminal server hardware that you intend to use).

Step	Task (<i>continued</i>)
3	Keep the default terminal settings on the S6000 console as follows: <ul style="list-style-type: none">• 9600 baud rate• No parity• 8 data bits• 1 stop bit• No flow control

Accessing the USB-B Console Port

The terminal settings are the same for the USB-B port and the console port:

- 9600 baud rate
- No parity
- 8 data bits
- 1 stop bit
- No flow control

When you connect the USB-B port, it becomes the primary connection and, when the system is connected, it sends all messages to the USB-B port.

Figure 7-2. USB-B Console Port Connector

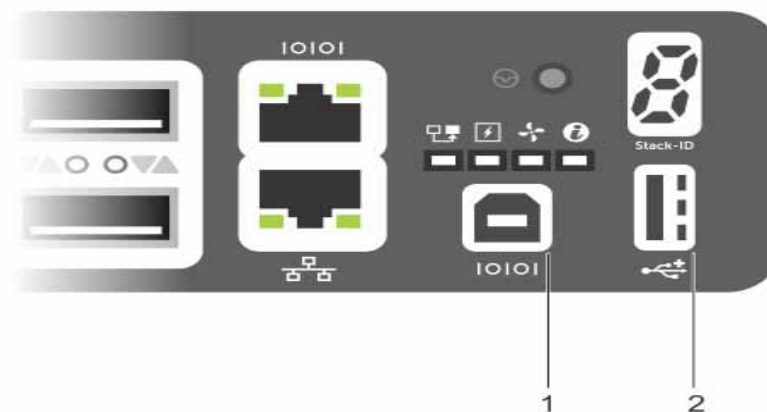

1 - USB-B port

2 - USB-A port

 **NOTE:** Before starting this procedure, be sure you have a terminal emulation program already installed on your PC. You will need to install appropriate drivers to support the USB-B port. For assistance, contact Dell Networking Technical Support.

To access the USB-B console port, follow these steps:

Step	Task
1	Power on the PC (Dell Networking recommends using the XP operating system).
2	Connect the USB-A end of cable into an available USB port on the PC.
3	Connect the USB-B end of cable into the USB-B console port on the S6000.
4	Power on the S6000.
5	Install the necessary USB device drivers (you will need an internet connection). For assistance, contact Dell Networking Technical Support.
6	Open your terminal software emulation program to access the S6000.
7	Keep the default terminal settings on the S6000 console as follows: <ul style="list-style-type: none">• 9600 baud rate• No parity• 8 data bits• 1 stop bit• No flow control
The CLI prompt appears (FTOS>_) when you are connected to the S6000.	

Default Configuration

A version of FTOS is pre-loaded onto the S6000 system; however, the switch is not configured when you power it up for the first time (except for the default host name, which is FTOS). You must configure the switch using the CLI.

Specifications

This chapter contains the following sections:

- [Chassis Physical Design](#)
- [Environmental Parameters](#)
- [Power Requirements](#)
- [IEEE Standards](#)
- [Agency Compliance](#)

△ Caution: Operate the product at an ambient temperature not higher than 40°C.

△ Lithium Battery Caution: There is a danger of explosion if the battery is incorrectly replaced. Replace only with same or equivalent type. Dispose of the batteries according to the manufacturer's instructions.

Chassis Physical Design

Parameter	Specifications
Height	1.71 inches (43.5 mm)
Width	17.08 inches (434 mm)
Depth	18.11 inches (460 mm)
Weight	16.12 lbs (7.32 kg)

Environmental Parameters

Parameter	Specifications
Operating temperature	32° to 113°F (0° to 45°C)
Operating humidity	5 to 90% (RH), non-condensing
Storage temperature	-40° to 158°F (-40° to 70°C)
Storage humidity	5 to 95% (RH), non-condensing
Maximum thermal output	419.7 BTU/hr

Power Requirements

The following tables represent the PSU's capabilities and do not represent the S6000's operation.

AC Input Specification

Parameter	Specifications
Power supply	100–240 VAC 50/60 Hz
Maximum current draw per system	2.9 A @ 280 watts/100vac 1.4 A @ 280 watts/200vac
Maximum power consumption	286 Watts
Reliability	MTBF 355,178 hours

DC Input Specification.

min/max input voltage range	-40.5V /-48V/ -60V
input power at full load	-40.5V/970W -48V/930W -60V/ 950W (without fan) -40.5V/980W -48V/940W -60V/ 960W (with fan)
input current at full load	-40.5V/23.8A -48V/19.0A -60V/ 15.6A (without fan) -40.5V/24A -48V/19.2A -60V/ 16.0A (with fan)
Start up VDC	39.0+/-1.5V
Start off VDC	37.5+/-1.5V

IEEE Standards

The S6000 system complies with the following IEEE standards:

- 802.1AB LLDP
- 802.1ag Connectivity fault Management
- 802.1D Bridging, STP
- 802.1p L2 Prioritization
- 802.1Q VLAN Tagging, Double VLAN Tagging, GVRP
- 802.1s MSTP
- 802.1w RSTP
- 802.3ab Gigabit Ethernet (1000BASE-T)
- 802.3ac Frame Extensions for VLAN Tagging
- 802.3ad Link Aggregation with LACP
- 802.3ae 10 Gigabit Ethernet (10GBASE-X)

- 802.3ba 40 Gigabit Ethernet (40GBase-SR4, 40GBase-CR4) on optical ports
- 802.3u Fast Ethernet (100BASE-TX)
- 802.3x Flow Control
- 802.3z Gigabit Ethernet (1000BASE-X)
- ANSI/TIA-1057 (LLDP-MED)
- Dell Networking (PVST+)
- MTU (12,000 bytes)

Agency Compliance

Network Equipment Building Systems (NEBS) Compliance

- Use shielded cables for ports 0 - 31. Ground the shields at both ends.
- Use only reverse airflow configurations in a NEBS-compliant installation.
- Fit the power supplies and fan modules with filter kits. Replace the fan filters on a regular basis.
- Use this equipment with an external, second-level 6kV lightning surge protective device (SPD) at the AC input of the building.
- Use a SPD with the AC power connections in order to protect the AC power supplies from damage from excessive power line surges.
- In order to comply with the GR-1089 Lightning Criteria for Equipment Interfacing with AC Power Ports, use a SPD at the AC input of the router.

 **WARNING:** ESD damage can occur if components are mishandled. Always wear an ESD-preventive wrist or heel ground strap when handling the S6000 and its components.

USA Federal Communications Commission (FCC) Statement

This equipment has been tested and found to comply with the limits for a Class A digital device, pursuant to Part 15 of the FCC rules. These limits are designated to provide reasonable protection against harmful interference when the equipment is operated in a commercial environment. This equipment generates, uses, and can radiate radio frequency energy. If it is not installed and used in accordance to the instructions, it may cause harmful interference to radio communications. Operation of this equipment in a residential area is likely to cause harmful interference, in which case users will be required to take whatever measures necessary to correct the interference at their own expense.

Properly shielded and grounded cables and connectors must be used in order to meet FCC emission limits. Dell Networking is not responsible for any radio or television interference caused by using other than recommended cables and connectors or by unauthorized changes or modifications in the equipment. Unauthorized changes or modification could void the user's authority to operate the equipment.

This device complies with Part 15 of the FCC Rules. Operation is subject to the following two conditions: (1) this device may not cause harmful interference, and (2) this device must accept any interference received, including interference that may cause undesired operation.

Canadian Department of Communication Statement

Industry Canada Class A emission compliance statement

This Class A digital apparatus complies with Canadian ICES-003.

Avis de conformité à la réglementation d'Industrie Canada

Cet appareil numérique de la classe A est conforme à la norme NMB-003 du Canada.

European Union EMC Directive Conformance Statement

This product is in conformity with the protection requirements of EU Council Directive 2004/108/EC on the approximation of the laws of the Member States relating to electromagnetic compatibility. Force 10 Networks can not accept responsibility for any failure to satisfy the protection requirements resulting from a non-recommended modification of this product, including the fitting of non-Dell Networking option cards.

This product has been tested and found to comply with the limits for Class A Information Technology Equipment according to CISPR 22/European Standard EN 55022. The limits for Class A equipment were derived for commercial and industrial environments to provide reasonable protection against interference with licensed communication equipment.

⚠ WARNING: This is a Class A product. In a domestic environment, this device may cause radio interference, in which case, you may be required to take adequate measures.

VORSICHT: Trennen Sie vor dem Entfernen des Netzteils das Netzstromkabel.

VORSICHT: Trennen Sie vor der Aufnahme von Wartungsarbeiten alle Stromkabel.

Anmerkung:

Das Gerät ist nicht für die Benutzung im unmittelbaren Gesichtsfeld am Bildschirmarbeitsplatz vorgesehen.

VORSICHT:

Gleit-/schienengeführte Geräte sollen nicht als Regal oder Arbeitsfläche verwendet werden.

Japan: VCCI Compliance for Class A Equipment

この装置は、情報処理装置等電波障害自主規制協議会（VCCI）の基準に基づくクラスA情報技術装置です。この装置を家庭環境で使用すると電波妨害を引き起こすことがあります。この場合には使用者が適切な対策を講ずるよう要求されることがあります。

This is Class A product based on the standard of the Voluntary Control Council For Interference by Information Technology Equipment (VCCI). If this equipment is used in a domestic environment, radio disturbance may arise. When such trouble occurs, the user may be required to take corrective actions.

⚠ WARNING: Use the AC power cords with Dell Networking equipment only. Do not use Dell Networking AC power cords with any unauthorized hardware.

本製品に同梱いたしております電源コードセットは、本製品専用です。
 本電源コードセットは、本製品以外の製品ならびに他の用途でご使用いただくことは出来ません。製品本体には同梱された電源コードセットを使用し、他製品の電源コードセットを使用しないで下さい。

Korean Certification of Compliance

<p>A급 기기 (업무용 방송통신기자재)</p>	<p>이 기기는 업무용(A급) 전자파적합기기로서 판매자 또는 사용자는 이 점을 주의하시기 바라며, 가정외의 지역에서 사용하는 것을 목적으로 합니다.</p>
--------------------------------	--

Korean Package Label

	 <i>[equipment type]</i>
<p>품명(Product Name)</p>	<p>Ethernet Switch</p>
<p>모델명(Model)</p>	<p><i>[model number]</i></p>
<p>신청인(Applicant)</p>	<p>Force10 Networks, Inc.</p>
<p>제조사(Manufacturer)</p>	<p>Delta Networks, (Dongguan) Ltd.</p>
<p>제조년월(Manufacturing Date)</p>	<p><i>[date]</i></p>
<p>제조국(Country of Origin)</p>	<p>China</p>

Safety Standards and Compliance Agency Certifications

- CUS UL 60950-1, 2nd Edition
- CSA 60950-1-03, 2nd Edition
- EN 60950-1:2006 +A1:2010+A11:2009 +A12:2011/IEC 60950-1:2005 EN 62311:2008
- EN 60825-1, 1st Edition
- EN 60825-1 Safety of Laser Products—Part 1: Equipment Classification Requirements and User’s Guide
- EN 60825-2 Safety of Laser Products—Part 2: Safety of Optical Fibre Communication Systems
- FDA Regulation 21CFR 1040.10 and 1040.11
- IEC 60950-1, 2nd Ed, including all National Deviations and Group Differences

Electromagnetic Compatibility (EMC)

Emissions

- International: CISPR 22: 2006, Class A
- Australia/New Zealand: AS/NZS CISPR 22:2009, Class A
- Canada: ICES-003, Issue-4, Class A
- Europe: EN55022 2006 (CISPR 22: 2006), Class A
- Japan: V3/2012.04 Class A
- USA: FCC CFR47 Part 15, Subpart B, Class A

Immunity

- EN300 386 V1.4.1:2008 EMC for Network Equipment
- EN 55022:2006 +A1:2007/CISPR 22:2009 (Class A)
- EN 55024:1998 +A1:2001 +A2:2003
- EN 61000-3-2:2006 +A2:2009
- EN 61000-3-3:2008
- EN 61000-4-2 ESD
- EN 61000-4-3 Radiated Immunity
- EN 61000-4-4 EFT
- EN 61000-4-5 Surge
- EN 61000-4-6 Low Frequency Conducted Immunity
- EN 300 386 V1.4.1:2008
- RoHS: Directive 2011/65/EU

Product Recycling and Disposal

Recycle or discard this system according to applicable local and national regulations. Dell Networking encourages owners of information technology (IT) equipment to responsibly recycle their equipment when it is no longer needed. Dell Networking offers a variety of product return programs and services in several countries to assist equipment owners in recycling their IT products.

Waste Electrical and Electronic Equipment (WEEE) Directive for Recovery, Recycle and Reuse of IT and Telecommunications Products

Dell Networking switches are labeled in accordance with European Directive 2002/96/EC concerning waste electrical and electronic equipment (WEEE). The Directive determines the framework for the return and recycling of used appliances as applicable throughout the European Union. This label is applied to various products to indicate that the product is not to be thrown away, but rather reclaimed upon end of life per this Directive.

Figure 8-1. The European WEEE symbol



In accordance with the European WEEE Directive, electrical and electronic equipment (EEE) is to be collected separately and to be reused, recycled, or recovered at end of life. Users of EEE with the WEEE marking per Annex IV of the WEEE Directive, as shown above, must not dispose of end of life EEE as unsorted municipal waste, but use the collection framework available to customers for the return, recycling and recovery of WEEE. Customer participation is important to minimize any potential effects of EEE on the environment and human health due to the potential presence of hazardous substances in EEE.

Dell Networking products, which fall within the scope of the WEEE, are labeled with the crossed-out wheelie-bin symbol, as shown above, as required by WEEE.

For information on Dell Networking product recycling offerings, see the WEEE Recycling instructions on iSupport.

For more information, contact the Dell Networking Technical Assistance Center (TAC) (see [Contacting the Technical Assistance Center](#)).

Technical Support

This chapter contains the following sections:

- [The iSupport Website](#)
- [Contacting the Technical Assistance Center](#)
- [Requesting a Hardware Replacement](#)

The iSupport Website

iSupport provides a range of documents and tools to assist you with effectively using Dell Networking equipment and mitigating the impact of network outages. Through iSupport you can obtain technical information regarding Dell Networking products, access to software upgrades and patches, and open and manage your technical assistance center (TAC) cases. Dell iSupport provides integrated, secure access to these services.

Accessing iSupport Services

The URL for iSupport is <http://support.dell.com/>. You must have a userid and password to access iSupport services.

To request a userid and password, follow these steps:

Step	Task
1	On the Dell Networking Support page, click the Account Request link.
2	Fill out the User Account Request form and click Send . You will receive your userid and password by E-mail.
3	To access iSupport services, click the LOGIN link and enter your userid and password.

Contacting the Technical Assistance Center

How to Contact Dell Networking TAC	Log in to iSupport at http://support.dell.com/ and select the Service Request tab.
Information to Submit When Opening a Support Case	<ul style="list-style-type: none"> • Your name, company name, phone number, and E-mail address • Preferred method of contact • Model number • Software version number • Symptom description • Screen shots showing the symptom, including any error messages. This can include: <ul style="list-style-type: none"> • Output from the show tech-support [non-paged] command (This report is very long so set the storage buffer in your terminal program to high.) • Output from the show logging eventlog [unit] command, where unit is the stack ID of the member unit that experienced the failure (This report is included as a section in the output of the show tech-support [non-paged] command.) • Console captures showing the error messages • Console captures showing the troubleshooting steps taken • Saved messages to a syslog server, if you use one
Managing Your Case	Log in to iSupport and select the Service Request tab to view all open cases and Return Materials Authorizations (RMAs).
Downloading Software Updates	Log in to iSupport and select the Software Center tab.
Technical Documentation	Log in to iSupport and select the Documents tab. You can access this page without logging in using the Documentation link on the iSupport page.
Contact Information	<p>E-mail: Dell-Force10_Technical_Support@Dell.com</p> <p>Web: http://support.dell.com/.</p> <p>Telephone:</p> <ul style="list-style-type: none"> • US and Canada: 866.965.5800 • International: 408.965.5800

Requesting a Hardware Replacement

To request replacement hardware, follow these steps:

Step	Task
1	Determine the part number and serial number of the component. To list the numbers for all components installed in the chassis, use the show hardware command.
2	Request an RMA number from TAC by opening a support case. Open a support case by: <ul style="list-style-type: none">• Using the Create Service Request form on the iSupport page (see Contacting the Technical Assistance Center).• Contacting Dell Networking directly by E-mail or by phone (see Contacting the Technical Assistance Center). Provide the following information when using E-mail or phone:<ul style="list-style-type: none">• Part number, description, and serial number of the component.• Your name, organization name, telephone number, fax number, and E-mail address.• Shipping address for the replacement component, including a contact name, phone number, and E-mail address.• A description of the failure, including log messages. This can include:<ul style="list-style-type: none">– Output from the show tech-support [non-paged] command (This report is very long so set the storage buffer in your terminal program to high.)– Output from the show logging eventlog [unit] command, where unit is the stack ID of the member unit that experienced the failure (This report is included as a section in the output of show tech-support [non-paged] command.)– Console captures showing the error messages– Console captures showing the troubleshooting steps taken– Saved messages to a syslog server, if you use one



Printed in the U.S.A.

www.dell.com | support.dell.com